

Product Specification

Preliminary Specification

Final Specification

Module	16.2" Color TFT-LCD
Model Name	H162HTX

Customer	Date
_____	_____
Approved by	
_____	_____

Approved by	Date
_____	_____
Prepared by	Date
_____	_____

Note: This Specification is subject to change without notice.

Product Specification

Contents

1 Handling Precautions	4
2 General Description	5
2.1 Display Characteristics.....	5
2.2 Absolute Maximum Rating of Environment.....	6
2.3 Optical Characteristics	7
3 TFT-LCD Module	11
3.1 Block Diagram	11
3.2 Interface Connection	12
3.2.1 Connector Type	12
3.2.2 Connector Pin Assignment	12
3.3 Electrical Characteristics.....	14
3.3.1 Absolute Maximum Rating	14
3.3.2 Recommended Operating Condition	14
3.4 Signal Characteristics	15
3.4.1 LCD Pixel Format	15
3.4.2 LVDS Data Format.....	15
3.4.3 Color versus Input Data.....	16
3.4.4 LVDS Specification	17
3.4.5 Input Timing Specification	19
3.4.6 Input Timing Diagram	20
3.5 Power ON/OFF Sequence.....	21
4 Backlight Unit	22
4.3.1 Absolute Maximum Rating	26
4.3.2 Recommended Operating Condition	26
5 Reliability Test	28
6 Shipping Label	29
7 Mechanical Characteristics	30
8 Packing Specification	31
8.1 Packing Flow.....	31
8.2 Pallet and shipment information	32

Product Specification

1 Handling Precautions

- 1) Since front polarizer is easily damaged, pay attention not to scratch it.
- 2) Be sure to turn off power supply when inserting or disconnecting from input connector.
- 3) Wipe off water drop immediately. Long contact with water may cause discoloration or spots.
- 4) When the panel surface is soiled, wipe it with absorbent cotton or other soft cloth.
- 5) Since the panel is made of glass, it may break or crack if dropped or bumped on hard surface.
- 6) Since CMOS LSI is used in this module, take care of static electricity and insure human earth when handling.
- 7) Do not open or modify the Module Assembly.
- 8) Do not press the reflector sheet at the back of the module to any directions.
- 9) In case a TFT-LCD Module has to be put back into the packing container slot after once it was taken out from the container, do not press the center of the LED lightbar edge. Otherwise the TFT-LCD Module may be damaged.
- 10) Insert or pull out the interface connector, be sure not to rotate nor tilt it of the TFT-LCD Module.
- 11) Do not twist nor bend the TFT -LCD Module even momentary. It should be taken into consideration that no bending/twisting forces are applied to the TFT-LCD Module from outside. Otherwise the TFT-LCD Module may be damaged.
- 12) Please avoid touching COF position while you are doing mechanical design.
- 13) When storing modules as spares for a long time, the following precaution is necessary:
Store them in a dark place. Do not expose the module to sunlight or fluorescent light. Keep the temperature between 5°C and 35°C at normal humidity.

Product Specification

2 General Description

This specification applies to the 16.2 inch wide Color a-Si TFT-LCD Module HT162HTX-500. The display supports the (1366(H) x 153(V)) screen format and 16.7M colors (RGB 6-bits + Hi-FRC data). The input interface is Dual channel LVDS and this module doesn't contain an driver board for backlight.

2.1 Display Characteristics

The following items are characteristics summary on the table under 25°C condition:

ITEMS	Unit	SPECIFICATIONS
Screen Diagonal	[mm]	411.5 (16.2")
Active Area	[mm]	409.80(H) × 46.08(V)
Pixels H x V	-	1366× 3(RGB) × 153
Pixel Pitch	[mm]	0.3(per one triad) × 0.3
Pixel Arrangement	-	R.G.B. Vertical Stripe
Display Mode	-	Normally White
White Luminance (Center)	[cd/m ²]	500 (Typ.)
Contrast Ratio	-	1000 : 1 (Typ.)
Response Time	[msec]	5 (Typ., on/off)
Power Consumption (LCD Module + Backligh unit)	[Watt]	10(Typ.)
Weight	[Grams]	1000 (Typ.)
Outline Dimension	[mm]	436.8(H) x 76.1(V) x 10.3(D) (Typ.)
Electrical Interface	-	S8 Channel LVDS
Support Color	-	16.7M colors
Surface Treatment	-	Anti-glare type, Hardness 3H
Temperature Range Operating	[°C]	0 to +50
Storage (Shipping)	[°C]	-20 to +60
RoHS Compliance	-	RoHS Compliance
TCO Compliance	-	TCO6.0 Compliance

Product Specification

2.2 Absolute Maximum Rating of Environment

Permanent damage may occur if exceeding the following maximum rating.

Symbol	Description	Min.	Max.	Unit	Remark
TOP	Operating Temperature	0	+50	[°C]	Note 2-1
TGS	Glass surface temperature (operation)	0	+65	[°C]	Note 2-1 Function judged only
HOP	Operation Humidity	5	90	[%RH]	Note 2-1
TST	Storage Temperature	-20	+60	[°C]	
HST	Storage Humidity	5	90	[%RH]	

Note 2-1: Temperature and relative humidity range are shown as the below figure.

1. 90% RH Max ($T_a \leq 39^\circ\text{C}$)
2. Max wet-bulb temperature at 39°C or less. ($T_a \leq 39^\circ\text{C}$)
3. No condensation

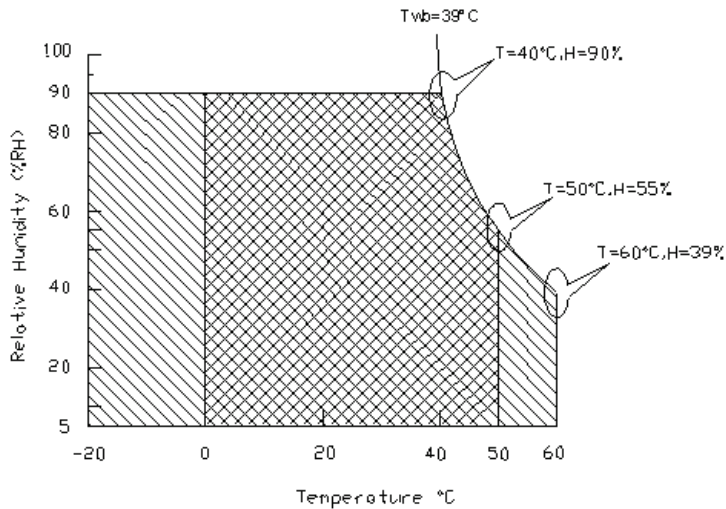

Operating Range



Storage Range

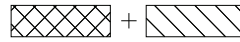

Product Specification

2.3 Optical Characteristics

The optical characteristics are measured on the following test condition.

Test Condition:

1. Equipment setup: Please refer to **Note 2-2**.
2. Panel Lighting time: 30 minutes
3. VDD=5.0V, Fv=60Hz, Is=60mA, Ta=25°C

Symbol	Description		Min.	Typ.	Max.	Unit	Remark
L _w	White Luminance (Center of screen)		200	500	-	[cd/m ²]	Note 2-2 By SR-3
L _{uni}	Luminance Uniformity (9 points)		75	80	-	[%]	Note 2-3 By SR-3
CR	Contrast Ratio (Center of screen)		600	1000	-	-	Note 2-4 By SR-3
θ _R	Horizontal Viewing Angle (CR=10)	Right	75	89	-	[degree]	Note 2-5 By SR-3
θ _L		Left	75	89	-		
Φ _H	Vertical Viewing Angle (CR=10)	Up	70	89	-		
Φ _L		Down	70	89	-		
θ _R	Horizontal Viewing Angle (CR=5)	Right	75	89	-		
θ _L		Left	75	89	-		
Φ _H	Vertical Viewing Angle (CR=5)	Up	70	89	-		
Φ _L		Down	70	89	-		
T _R	Response Time	Rising Time	-	3.8	5.5	[msec]	Note 2-6 By TRD-100
T _F		Falling Time	-	1.2	2.5		
-		Rising + Falling	-	5	8		
R _x	Color Coordinates (CIE 1931)	Red x	0.615	0.645	0.675	-	By SR-3
R _y		Red y	0.303	0.333	0.363		
G _x		Green x	0.290	0.320	0.350		
G _y		Green y	0.596	0.626	0.656		
B _x		Blue x	0.123	0.153	0.183		
B _y		Blue y	0.027	0.057	0.087		
W _x		White x	0.283	0.313	0.343		
W _y		White y	0.299	0.329	0.359		
CT	Crosstalk		-	-	1.5	[%]	Note 2-7 By SR-3
F _{dB}	Flicker (Center of screen)		-	-	-20	[dB]	Note 2-8 By SR-3

Product Specification

Note 2-2: Equipment setup :

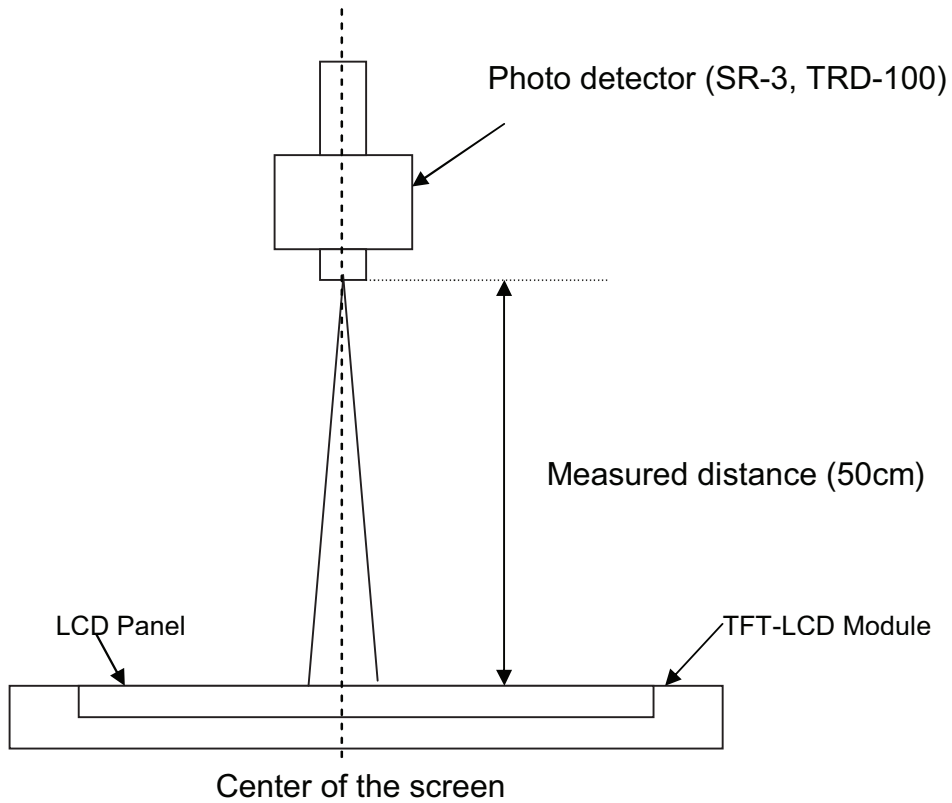

Note 2-3: Luminance Uniformity Measurement

Definition:

$$\text{Luminance Uniformity} = \frac{\text{Minimum Luminance of 9 Points (P1 ~ P9)}}{\text{Maximum Luminance of 9 Points (P1 ~ P9)}}$$

a. Test pattern: White Pattern

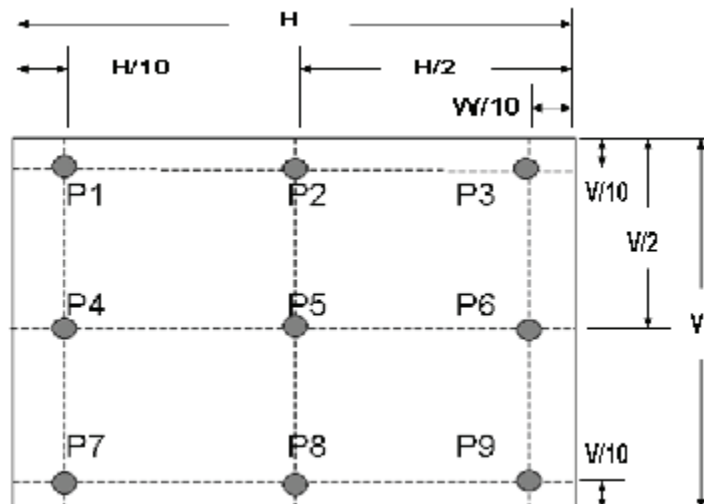

Product Specification

Note 2-4: Contrast Ratio Measurement

Definition:

$$\text{Contrast Ratio} = \frac{\text{Luminance of White pattern}}{\text{Luminance of Black pattern}}$$

- a. Measured position: Center of screen (P5) & perpendicular to the screen ($\theta = \Phi = 0^\circ$)

Note 2-5: Viewing angle measurement

Definition: The angle at which the contrast ratio is greater than 10 & 5 .

- a. Horizontal view angle: Divide to left & right (θ_L & θ_R)
 Vertical view angle: Divide to up & down (Φ_H & Φ_L)

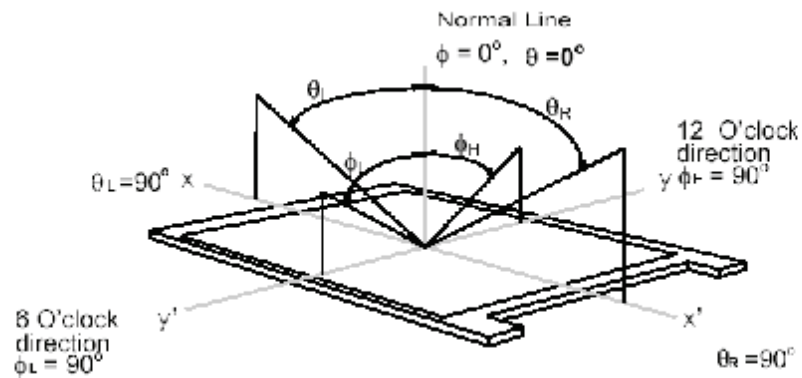

Note 2-6: Response time measurement

The output signals of photo detector are measured when the input signals are changed from "Black" to "White" (rising time, T_R), and from "White" to "Black" (falling time, T_F), respectively. The response time is interval between the 10% and 90% of optical response. (*Black & White color definition: Please refer section 3.4.3*)

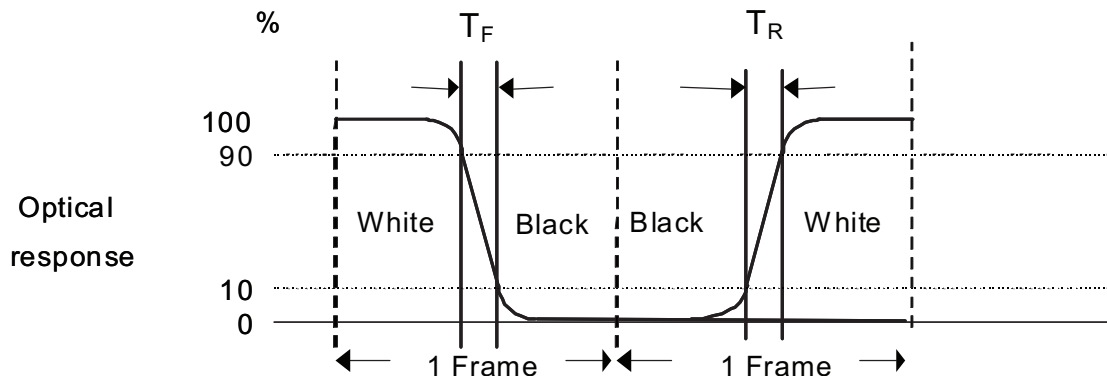

Product Specification

Note 2-7: Crosstalk measurement

Definition:

$$CT = \text{Max. } (CT_H, CT_V);$$

Where

a. Maximum Horizontal Crosstalk :

$$CT_H = \text{Max. } (|Y_{BL} - Y_{AL}| / Y_{AL} \times 100 \%, |Y_{BR} - Y_{AR}| / Y_{AR} \times 100 \%);$$

Maximum Vertical Crosstalk:

$$CT_V = \text{Max. } (|Y_{BU} - Y_{AU}| / Y_{AU} \times 100 \%, |Y_{BD} - Y_{AD}| / Y_{AD} \times 100 \%);$$

b. $Y_{AU}, Y_{AD}, Y_{AL}, Y_{AR}$ = Luminance of measured location without Black pattern

$Y_{BU}, Y_{BD}, Y_{BL}, Y_{BR}$ = Luminance of measured location with Black pattern

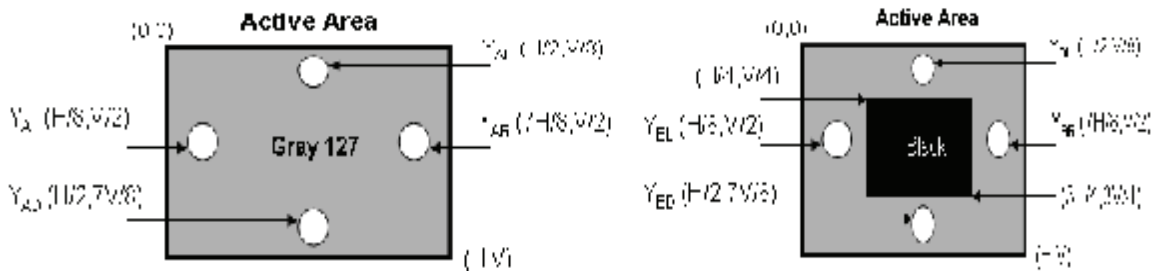

Note 2-8: Flicker measurement

a. Test pattern: It is listed as following.



Gray level = L0



Gray level = L127

R: Red, G: Green, B:Blue

b. Measured position: Center of screen (P5) & perpendicular to the screen ($\theta = \Phi = 0^\circ$)

Product Specification

3 TFT-LCD Module

3.1 Block Diagram

The following shows the block diagram of the Color TFT-LCD Module.

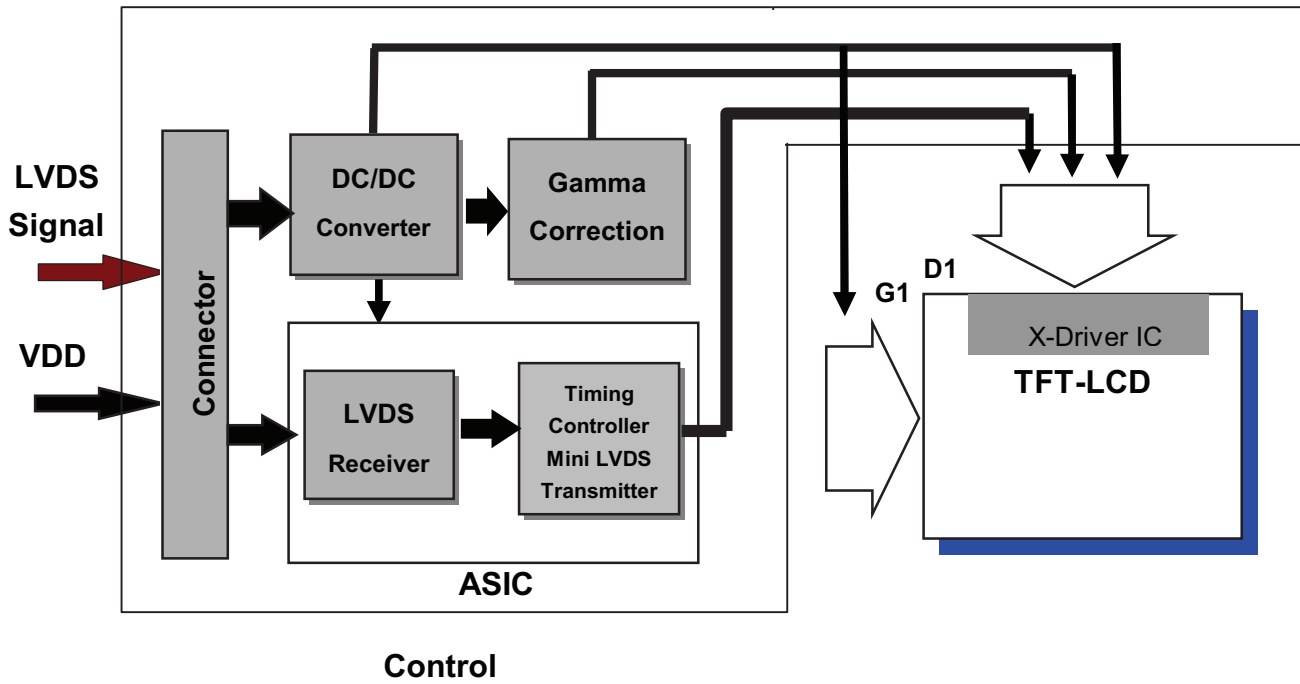

Product Specification

3.2 Interface Connection

3.2.1 Connector Type

3.2.2 Connector Pin Assignment

Pin No	Symbol	Function	Remark
1	NC	No connection	
2	CE	No connection	internal use
3	CTL	No connection	internal use
4	GND	GND Ground	
5	RX0-	Negative LVDS differential data input. Channel 0	
6	RX0+	Positive LVDS differential data input. Channel 0	
7	GND	Ground	
8	RX1-	Negative LVDS differential data input. Channel 1	
9	RX1+	Positive LVDS differential data input. Channel 1	
10	GND	Ground	
11	RX2-	Negative LVDS differential data input. Channel 2	
12	RX2+	Positive LVDS differential data input. Channel 2	
13	GND	Ground	
14	RXCLK-	Negative LVDS differential clock input.	
15	RXCLK+	Positive LVDS differential clock input.	
16	GND	Ground	
17	RX3-	Negative LVDS differential data input. Channel 3	
18	RX3+	Positive LVDS differential data input. Channel 3	
19	GND	Ground	
20	NC	Not connection, this pin should be open.	
21	NC	Not connection, this pin should be open.	
22	NC	Not connection, this pin should be open.	
23	GND	Ground	
24	GND	Ground	
25	GND	Ground	
26	VCC	5V Power supply	
27	VCC		
28	VCC		
29	VCC		
30	VCC		

Product Specification

3.3 Electrical Characteristics

3.3.1 Absolute Maximum Rating

Permanent damage may occur if exceeding the following maximum rating.

Symbol	Description	Min	Max	Unit	Remark
VDD	Power Supply Input Voltage	GND-0.3	6.0	[Volt]	Ta=25°C

3.3.2 Recommended Operating Condition

Symbol	Description	Min	Typ	Max	Unit	Remark
VDD	Power supply Input voltage	4.5	5.0	5.5	[Volt]	
IDD	Power supply Input Current (RMS)	-	0.6	0.72	[A]	VDD= 5.0V, Black Pattern, Fv=60Hz
			0.72	0.87	[A]	VDD= 5.0V, Black Pattern, Fv=75Hz
PDD	VDD Power Consumption	-	3	3.6	[Watt]	VDD= 5.0V, Black Pattern, Fv=60Hz
			3.6	4.32	[Watt]	VDD= 5.0V, Black Pattern, Fv=75Hz
IRush	Inrush Current	-	-	3.0	[A]	Note 3-1
VDDrp	Allowable VDD Ripple Voltage	-	-	500	[mV]	VDD= 5.0V, Black Pattern, Fv=75Hz

Product Specification

3.4.4 LVDS Specification

a. DC Characteristics:

Symbol	Description	Min	Typ	Max	Units	Condition
V_{TH}	LVDS Differential Input High Threshold	-	-	+100	[mV]	$V_{CM} = 1.2V$
V_{TL}	LVDS Differential Input Low Threshold	-100	-	-	[mV]	$V_{CM} = 1.2V$
$ V_{ID} $	LVDS Differential Input Voltage	100	-	600	[mV]	
V_{CM}	LVDS Common Mode Voltage	+1.0	+1.2	+1.5	[V]	$V_{TH}-V_{TL} = 200mV$

LVDS Signal Waveform:

Use RxOCLK- & RxOCLK+ as example.

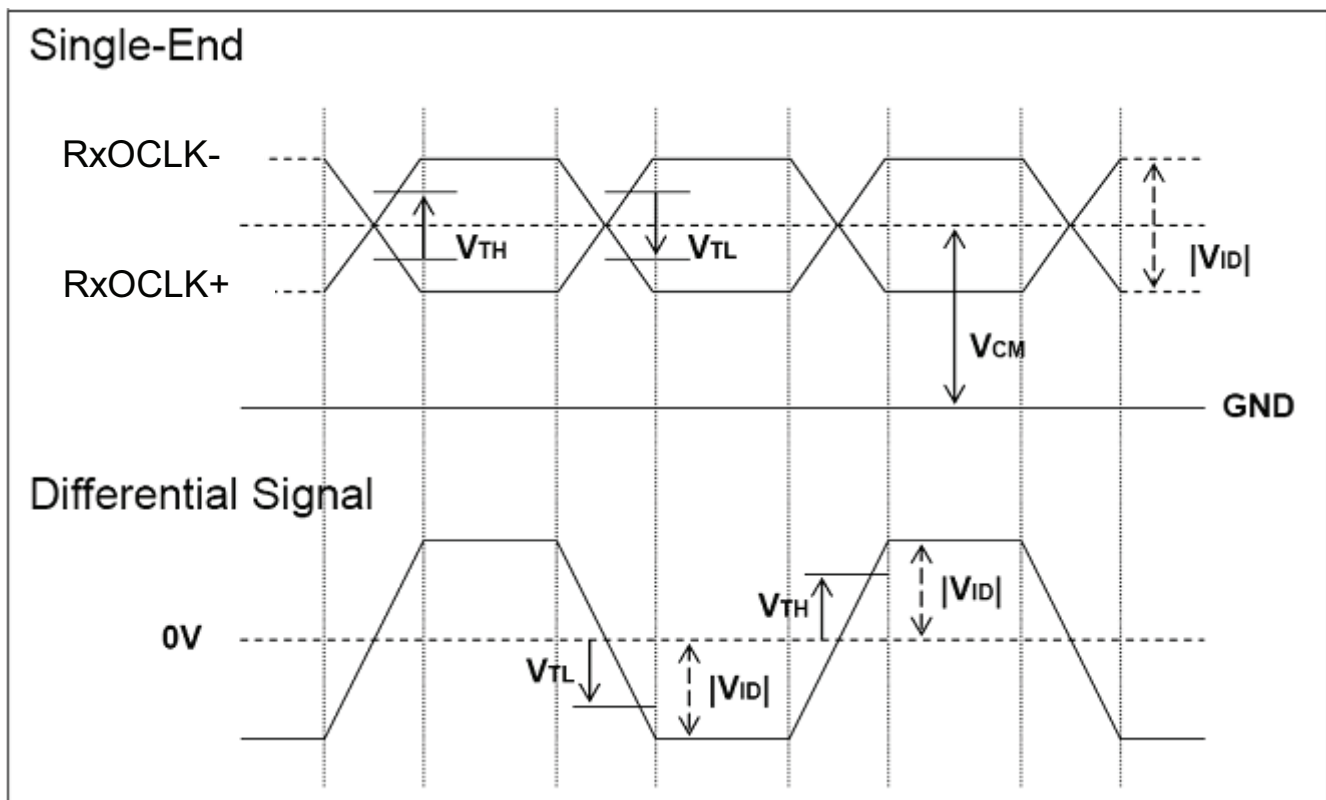

Product Specification

b. AC Characteristics:

Symbol	Description	Min	Max	Unit	Remark
F_{DEV}	Maximum deviation of input clock frequency during Spread Spectrum	-	± 3	%	
F_{MOD}	Maximum modulation frequency of input clock during Spread Spectrum	-	200	KHz	

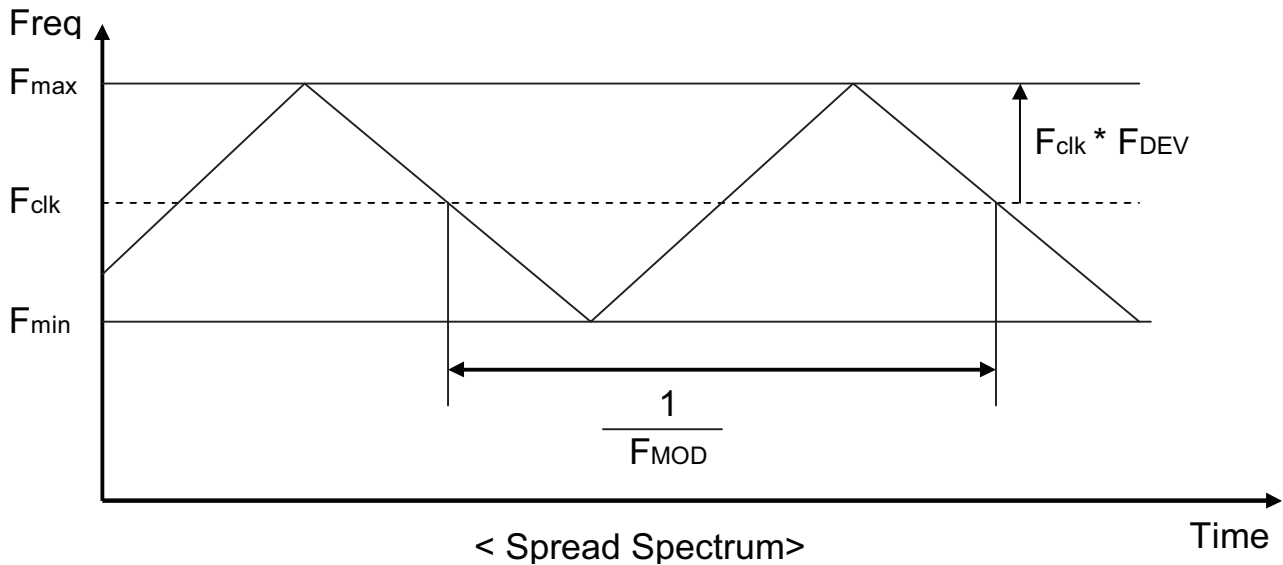

F_{clk} : LVDS Clock Frequency

Product Specification

3.4.5 Input Timing Specification

It only support DE mode, and the input timing are shown as the following table.

Symbol	Description		Min.	Typ.	Max.	Unit	Remark
Tv	Vertical Section	Period	1036	1066	1873	Th	
Tdisp (v)		Active	1024	1024	1024	Th	
Tblk (v)		Blanking	12	42	849	Th	
Fv		Frequency	50	60	76	Hz	
Th	Horizontal Section	Period	730	844	1320	Tclk	
Tdisp (h)		Active	640	640	640	Tclk	
Tblk (h)		Blanking	90	204	680	Tclk	
Fh		Frequency	51.8	64	93.7	KHz	Note 3-3
Tclk	LVDS Clock	Period	14.6	18.5	26	ns	1/Fclk
Fclk		Frequency	37.8	54	68.4	MHz	Note 3-4

Note 3-3: The equation is listed as following. Please don't exceed the above recommended value.

$$Fh \text{ (Min.)} = Fclk \text{ (Min.)} / Th \text{ (Min.)};$$

$$Fh \text{ (Typ.)} = Fclk \text{ (Typ.)} / Th \text{ (Typ.)};$$

$$Fh \text{ (Max.)} = Fclk \text{ (Max.)} / Th \text{ (Min.)};$$

Note 3-4: The equation is listed as following. Please don't exceed the above recommended value.

$$Fclk \text{ (Min.)} = Fv \text{ (Min.)} \times Th \text{ (Min.)} \times Tv \text{ (Min.)};$$

$$Fclk \text{ (Typ.)} = Fv \text{ (Typ.)} \times Th \text{ (Typ.)} \times Tv \text{ (Typ.)};$$

$$Fclk \text{ (Max.)} = Fv \text{ (Max.)} \times Th \text{ (Typ.)} \times Tv \text{ (Typ.)};$$

Product Specification

4.3 Electrical Characteristics

4.3.1 Absolute Maximum Rating

Permanent damage may occur if exceeding the following maximum rating.

(Ta=25°C)

Symbol	Description	Min	Max	Unit	Remark
Is	LED String Current	0		[mA]	100% duty ratio
				[mA]	Duty ratio ≤ 10% Pulse time=10 ms

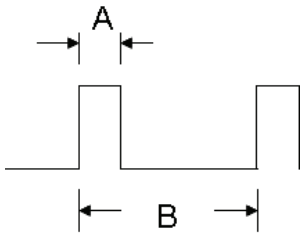

Duty ratio= (A / B) X 100% ; (A: Pulse time, B: Period)

4.3.2 Recommended Operating Condition

(Ta=25°C)

Symbol	Description	Min.	Typ.	Max.	Unit	Remark
Is	LED String Current	-			[mA]	100% duty ratio of LED chip
Vs	LED String Voltage				[Volt]	Is=60mA @ 100% duty ratio; Note 4-1 Note 4-5
ΔVs	Maximum Vs Voltage Deviation of light bar	-			[Volt]	Is=60mA @ 100% duty ratio; Note 4-2
P _{BLU}	LED Light Bar Power Consumption	-	22		[Watt]	Note 4-3
LT _{LED}	LED Life Time	50,000	-	-	[Hour]	Note 4-4

Product Specification

5 Reliability Test

reliability test items are listed as following table. (*Bare Panel only*)

Items	Condition	Remark
Temperature Humidity Bias (THB)	Ta= 50°C, 80%RH, 300hours	
High Temperature Operation (HTO)	Ta= 50°C, 50%RH, 300hours	
Low Temperature Operation (LTO)	Ta= 0°C, 300hours	
High Temperature Storage (HTS)	Ta= 60°C, 300hours	
Low Temperature Storage (LTS)	Ta= -20°C, 300hours	
Vibration Test (Non-operation)	Acceleration: 1.5 Grms Wave: Random Frequency: 10 - 200 Hz Sweep: 30 Minutes each Axis (X, Y, Z)	
Shock Test (Non-operation)	Acceleration: 50 G Wave: Half-sine Active Time: 20 ms Direction: ±X, ±Y, ±Z (one time for each Axis)	
Drop Test	Height: 61 cm, package test	
Thermal Shock Test (TST)	-20°C/30min, 60°C/30min, 100 cycles	Note 5-1
On/Off Test	On/10sec, Off/10sec, 30,000 cycles	
ESD (Electro Static Discharge)	Contact Discharge: ± 15KV, 150pF(330Ω) 1sec, 8 points, 25 times/ point.	Note 5-2
	Air Discharge: ± 15KV, 150pF(330Ω) 1sec 8 points, 25 times/ point.	
Altitude Test	Operation:18,000 ft Non-Operation:40,000 ft	

Note 5-1: a. A cycle of rapid temperature change consists of varying the temperature from -20 °C to 60°C, and back again. Power is not applied during the test.

b. After finish temperature cycling, the unit is placed in normal room ambient for at least 4 hours before power on.

Note 5-2: EN61000-4-2, ESD class B: Certain performance degradation allowed

No data lost

Self-recoverable

No hardware failures.

7 Mechanical Characteristics

